

# TV TROLLEY

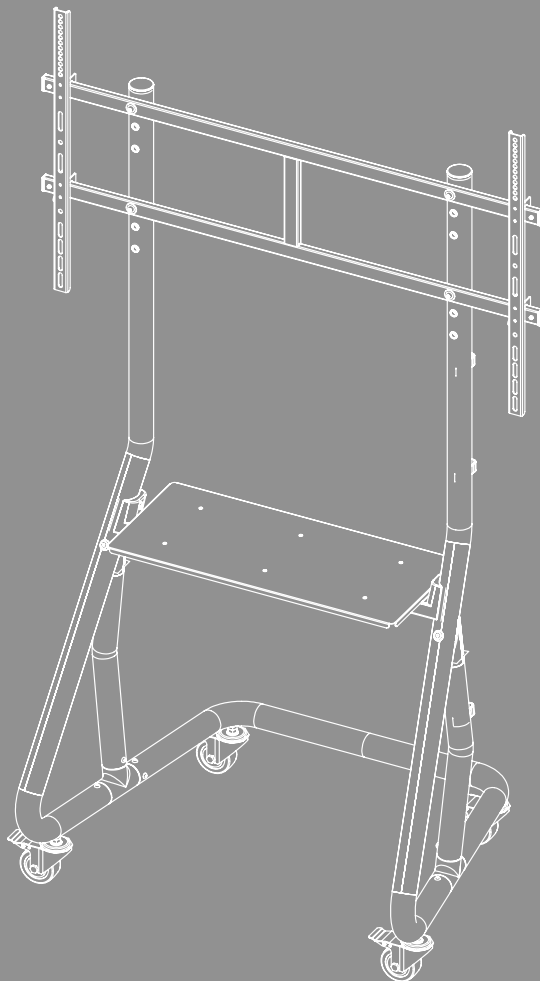



---

## Contents

1. Explanation of warning symbols and notes . . . . .	3
2. Package contents . . . . .	4
3. Additionally required tools . . . . .	5
4. Safety instructions . . . . .	5
5. Application and specifications . . . . .	6
6. Preparation and assembly . . . . .	6
6.1 Assembly preparation . . . . .	7
6.1.1 Fastening the shelf supports . . . . .	7
6.1.2 Assembling the feet . . . . .	8
6.1.3 Attaching the swivel castors . . . . .	8
6.1.4 Mounting the mounting plate . . . . .	8
6.1.5 Assembly of the shelf . . . . .	10
6.2 Mounting on the TV set . . . . .	11
6.2.1 Mount the VESA arms on the back of the TV set . . . . .	12
6.3 Mounting the TV on the TV trolley . . . . .	13
6.4 Cable management . . . . .	15
7. Adjustment & maintenance . . . . .	16
8. Setting options . . . . .	17
9. Technical data . . . . .	18
10. Warranty disclaimer . . . . .	19
11. Service and support . . . . .	19
12. Warranty conditions . . . . .	19



---

## GB Operating Instructions

Thank you for choosing a Hama product.

Take your time and read the following instructions and information completely. Please keep these instructions in a safe place for future reference. If you sell the device, pass on the illustrated quick start guide and the safety instructions in printed form to the new owner.

### 1. Explanation of warning symbols and notes

#### Warning



This symbol is used to indicate safety instructions or to draw your attention to specific hazards and risks.

#### Note



















This symbol is used to indicate additional information or important notes.

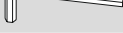

## 2. Package contents

- TV trolley (1x)
- Cable clips (3x)
- Shelf (1x)
- Mounting kit
- Safety instructions, illustrated quick start guide

### Mounting kit

<b>A1</b>		M8x35 (x6)	<b>C2</b>		M6x20 (x4)
<b>A2</b>		M8x15 (x1)	<b>D1</b>		M8x12 (x4)
<b>A3</b>		M6x10 (x6)	<b>D2</b>		M8x20 (x4)
<b>A4</b>		M6x16 (x2)	<b>D3</b>		M8x30 (x4)
<b>A5</b>		M8 (x4)	<b>D4</b>		M8x50 (x4)
<b>B1</b>		M6/M8 (x4)	<b>E1</b>		4 mm (x1)
<b>B2</b>		M8x10 (x4)	<b>E2</b>		5 mm (x1)
<b>B3</b>		M8x20 (x4)	<b>E3</b>		M10 (x1)
<b>C1</b>		M6x12 (x4)			

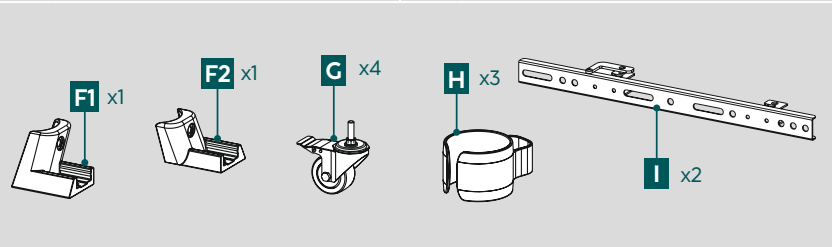

\* M8x50 + Ø8x5 = M8x45

### Note

Please check the mounting kit for completeness before installing the bracket and ensure that there are no faulty or damaged parts.





### 3. Additionally required tools



#### Note

Never install the bracket alone. Seek assistance and help!



### 4. Safety instructions

#### Warning



- Given the multitude of terminal devices available on the market, the supplied mounting kit is unable to cover every option.
- It occasionally happens that the screws for attaching the device to the bracket are too long.
- Read the operating instructions for your terminal device before attempting to mount it. The instructions provide information about the type and measurements of suitable fastening materials.
- If the supplied mounting kit does not contain suitable fastening materials for mounting the terminal device, purchase these from a specialised dealer.
- Never apply force during assembly. This can damage your device or the bracket.
- If in doubt, have this product installed by a qualified technician - do not attempt to install it yourself!
- Once you have mounted the product and the attached load, check that they are sufficiently secure and safe to use.
- You should repeat this check at regular intervals (at least every three months).
- Ensure that the product does not exceed its maximum permitted carrying capacity and that no load exceeding the maximum permitted dimensions is attached.
- Make sure that the product is loaded symmetrically.
- Maintain the necessary safety clearance around the attached load (depending on the model).
- In the event of damage to the product, remove the attached load and stop using the product.
- Do not attach any additional objects to the product.

#### Note – Commercial use



If the device is used commercially, increased duty of care requirements apply.

Please observe the accident prevention regulations of the German employer's liability insurance association for electrical systems and equipment. Please also observe all accident prevention regulations from other applicable employer's liability insurance associations and accident insurance companies, as well as any legal regulations applicable to the particular industry and/or location.

The bracket must be installed by trained personnel or a qualified professional.

Secure the product and the attached load against falling using suitable equipment (e.g. an arresting cable) and in accordance with locally applicable regulations.

Have trained personnel carry out regular inspections to ensure that the product is securely installed, properly functioning and in acceptable condition and document these checks.



---

## 5. Application and specifications

- The bracket is intended only for use inside buildings.
- Use the bracket only for the intended purpose.

## 6. Preparation and assembly

### Note





- Never install the bracket alone. Seek assistance and help!
- Different end devices have different connections for cabling and other devices. Before commencing the installation, check whether the necessary connections can still be reached after mounting.
- Depending on the product and mounting method, you may not need all parts of the mounting kit. It is therefore possible that unneeded screws and other small parts will be left over even after correct mounting. Keep these in a safe place together with these operating instructions for use for later reference (sale of the product, moving house, relocation of the bracket, new TV, etc.).

### Warning



- Only set the product up on even, non-slip surfaces with a sufficient load-bearing capacity for the product and the device attached to it.
- Make sure that children do not use the product for climbing.
- Note that the castors of the product can cause pressure marks on the installation surface. This depends on the weight loading and on the stability of the surface at the place of installation.
- Please note that subsequent height adjustment is only possible by dismantling the suspension fitting.



## 6.1 Assembly preparation

### 6.1.1 Fastening the shelf supports

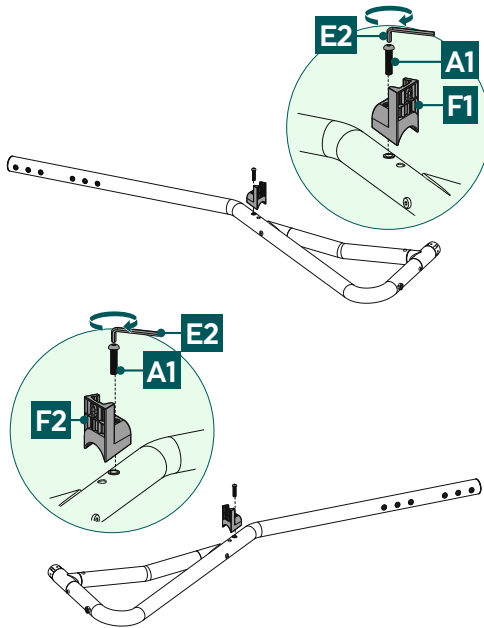

- Attach the shelf supports [F1] and [F2] to the two feet using the screws [A1]. Use the Allen key [E2] for this.



## 6.1.2 Assembling the feet

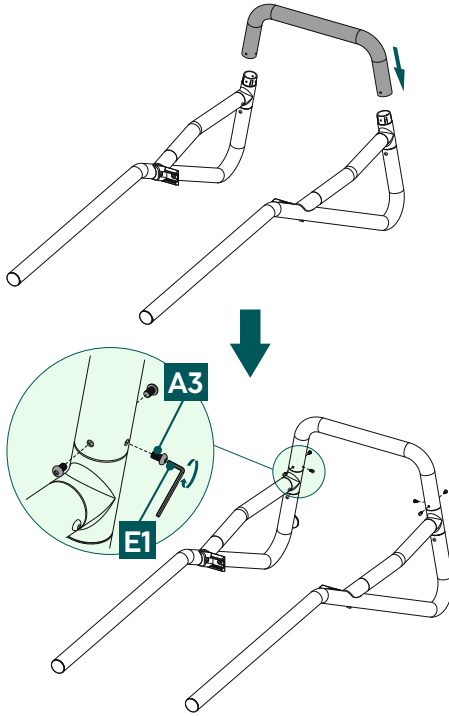

- Attach the lower connecting piece by placing it on the two feet. Make sure that the shelf supports are facing inwards. Use the screws [A3] and the enclosed Allen key [E1] for fastening.

## 6.1.3 Attaching the swivel castors

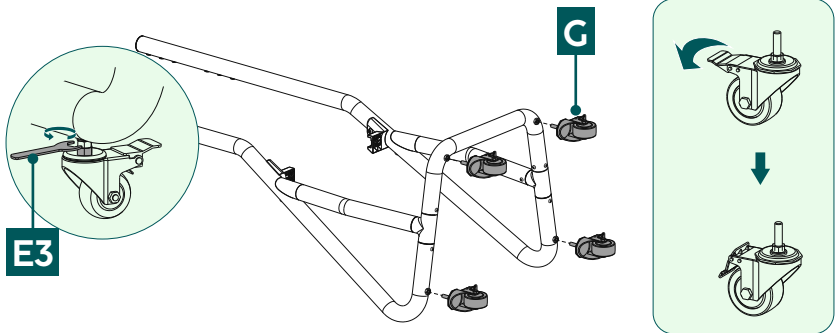

Attach the castors [G] to the underside of the TV trolley and secure them using the enclosed spanner [E3].

All four swivel castors have a parking brake.

Always lock the castors using the parking brakes as soon as the TV trolley is in the desired position.





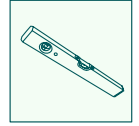
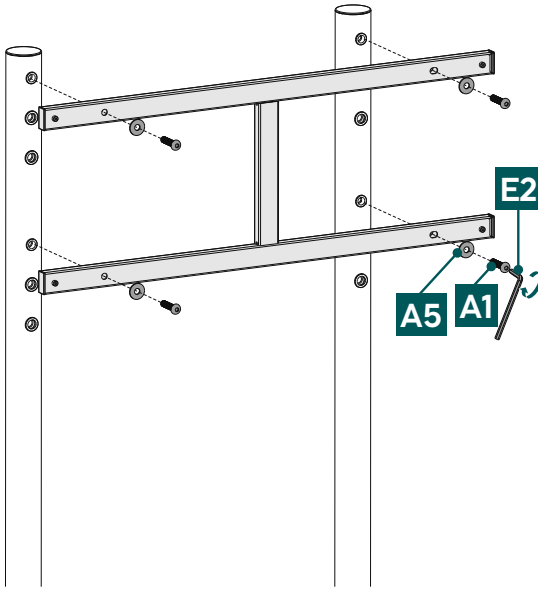

## 6.1.4 Mounting the mounting plate



- Position the mounting plate at the desired height\*. Use a spirit level to check the horizontal alignment.
- Fix the plate as shown above with the screws [A1] and washers [A5]. Use an Allen key [E2] for this assembly step.

\* Please note that subsequent height adjustment is only possible by dismantling the suspension fitting.

---

## 6.1.5 Assembly of the shelf

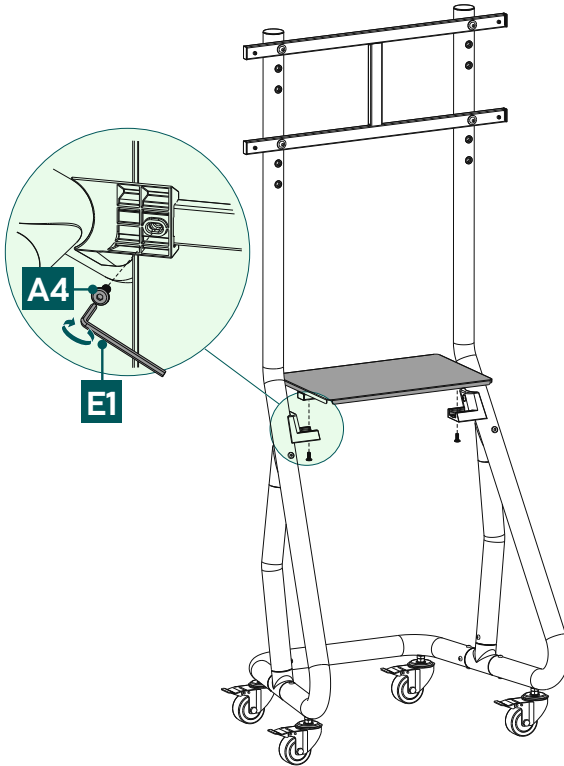

1. Place the shelf on the holders provided.
2. Secure the attached shelf as shown above using [A4] screws and the enclosed Allen key [E1].



## 6.2 Mounting on the TV set

### Note

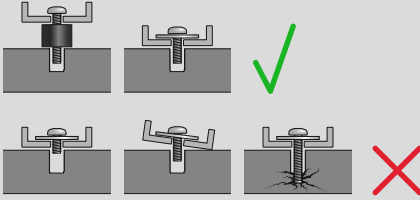

- Given the multitude of terminal devices structures available on the market, we cannot describe all possible mounting options here.
- Please ensure that the bracket lays flat and evenly on the back of the television.
- Use the enclosed spacer to even out any unevenness on the back of the television.
- Ensure that all screws have the proper length and can be mounted until they are hand-tight.

## 6.2.1 Mount the VESA arms on the back of the TV set

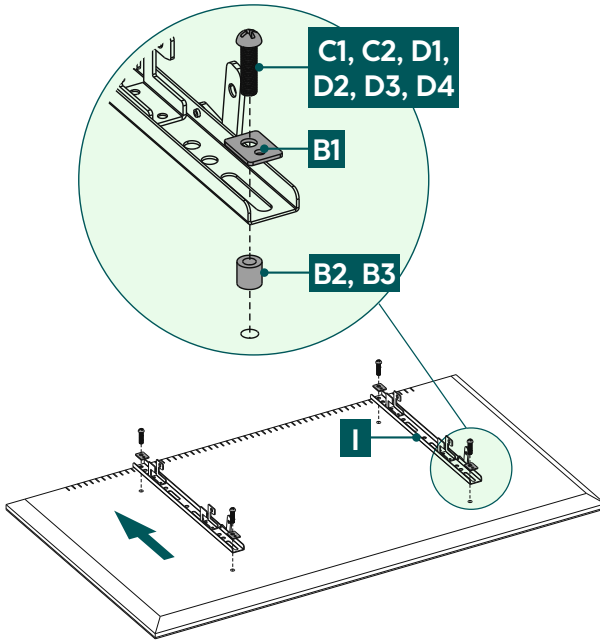

### Flat TV back

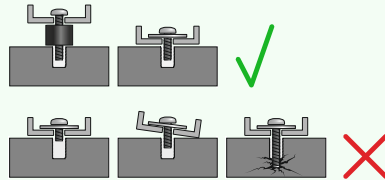
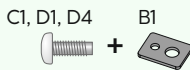

### Curved TV back

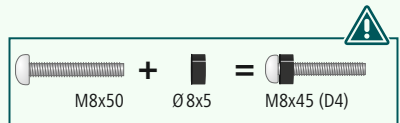
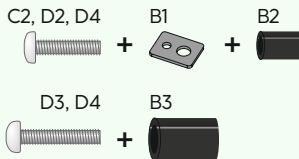

- Mount the VESA arms [I] to the back of your TV set.
- Ensure that the two VESA arms are correctly aligned. The four hooks inside the rail must point downwards.
- Note the combination of screw, washer and spacer listed above for your flat or curved TV.



### 6.3 Mounting the TV on the TV trolley

Get support and help from other people for the following assembly step.

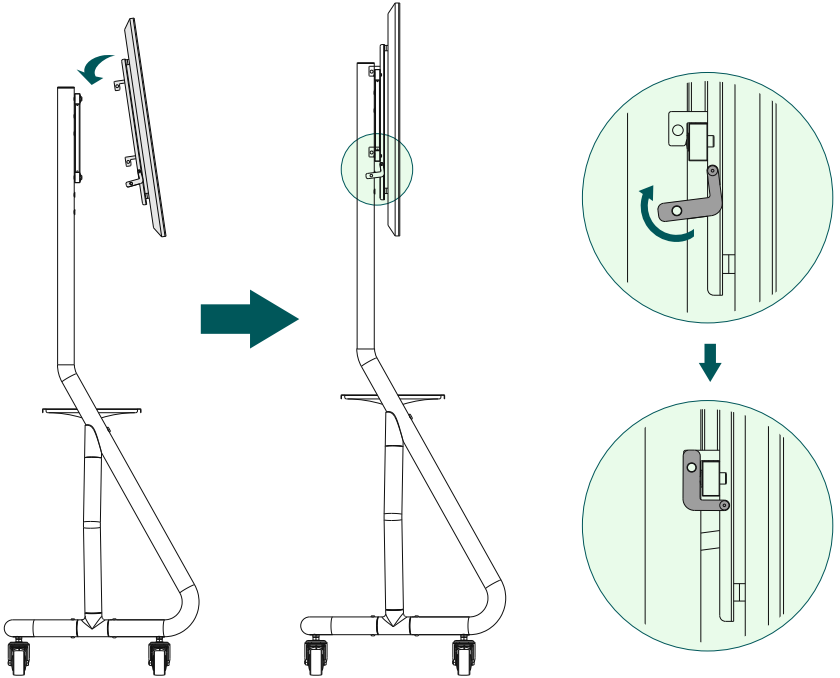

- Hang the TV set with the mounted VESA arms on the bracket as shown above.
- Turn the locking lever upwards to fix the TV to the bracket.

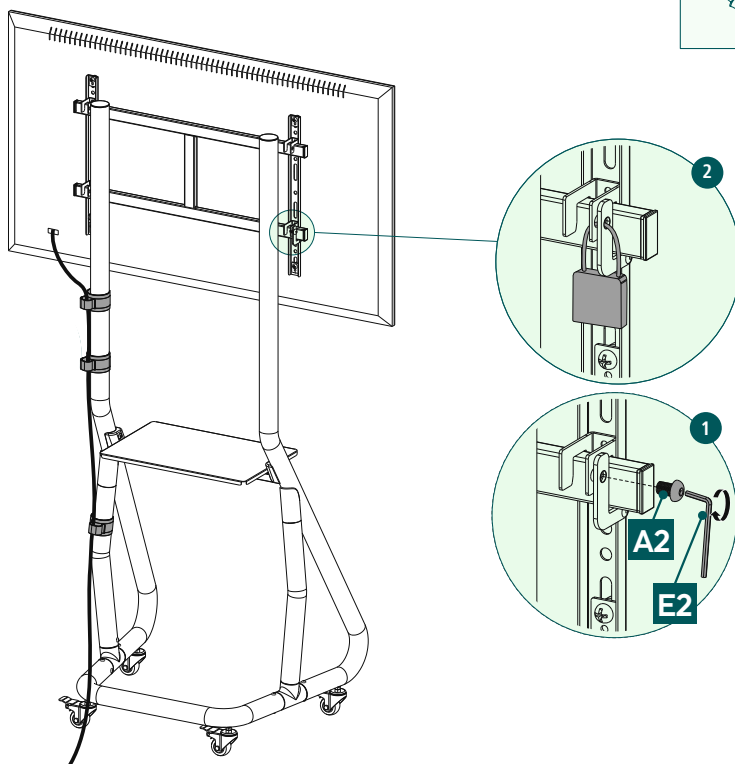

You now have two options for securing the TV to the bracket:

1. Secure the TV set by fixing the locking lever with the screw [A2]. Use the Allen key [E2] for this.
2. Secure the TV with a padlock (optional).  
\* The shackle diameter of the padlock must be 4 to 6 mm.  
Padlock not included in the extent of delivery.

Ensure that the TV trolley is only moved with the carrying arms secured.

## 6.4 Cable management

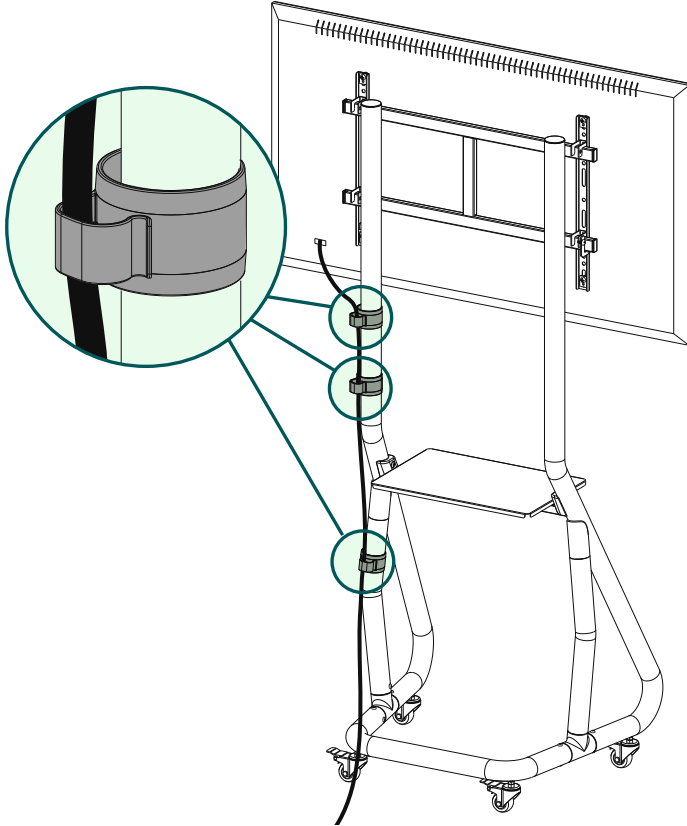

Attach the enclosed cable clips [H] to the support leg of the bracket. Guide the cables through the clips as shown above.



---

## 7. Adjustment & maintenance

### Note



Never adjust the bracket alone. Seek assistance and help!

### Note - tiltable / full-motion brackets



- Ensure that no electrical cables are crushed or damaged during installation or adjustment.
- During adjustment, ensure that the product is loaded symmetrically and that the maximum permitted carrying capacity is not exceeded.

### Note – Height adjustment



- To change the height of the TV set, the TV set including the support arms must be removed from the TV trolley.
- Ensure that the TV trolley is only moved with the carrying arms secured.
- Always lock the castors using the parking brakes as soon as the TV trolley is in the desired position.
- Check the strength and operational safety of the bracket and the load attached to it at regular intervals (at least quarterly).
- Clean only with water or conventional household cleaners.





## 8. Setting options

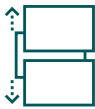
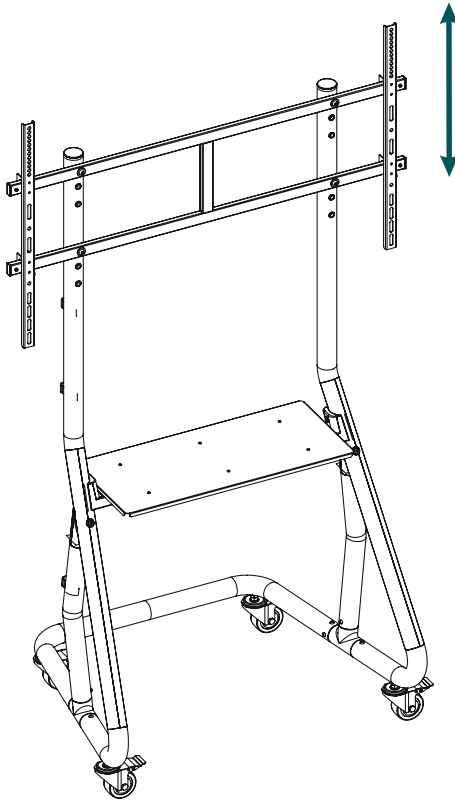

**TV 3x**  
height-adjustable

- To change the height of the TV set, the TV set including the support arms must be removed from the TV trolley. To do this, first unplug the TV set from the mains socket. Then loosen the securing screws or the padlock and remove the TV from the TV trolley. Now loosen the screws [A1] to remove the horizontal mounting plate. Carry out the assembly steps from **6.1.4 Mounting the mounting plate** again.



## 9. Technical data

Screen diagonal:	124.0 - 254.0 cm (US: 49" - 100")
Wall bracket load capacity:	80 kg
Shelf load capacity:	25 kg
Shelf dimensions:	63.4 x 28.0 cm
Height:	183.8 cm
Mount:	Compliant with VESA standard: 200 x 200 400 x 400 600 x 400 800 x 400 800 x 600 1000 x 600



---

## 10. Warranty disclaimer

Hama GmbH & Co KG assumes no liability and provides no warranty for damage resulting from improper installation/mounting, improper use of the product or from failure to observe the operating instructions and/or safety notes.

## 11. Service and support

Please contact Hama Product Consulting if you have any questions about this product.

Hotline: +49 9091 502-0 (German/English)

Further support information can be found here: [www.hama.com](http://www.hama.com)

## 12. Warranty conditions

For this product, HAMA GmbH & Co KG grants you an extended manufacturer's warranty for freedom from defects, usability, workmanship and the durability of the materials used for a period of 10 years. Excluded from the guarantee is the compatibility of the product with future standards of further developed hardware.

Within the specified period, Hama GmbH & Co KG will remedy a justified warranty claim at its own discretion, free of charge, either by repair or replacement.

The warranty period begins on the date of purchase of this product and is valid throughout the EU.

The warranty granted is in addition to and does not affect your statutory rights. Damage caused by improper use, normal wear and tear, exposure to chemicals or force majeure, as well as tampering or repairs by you or third parties, are excluded from the warranty.

Furthermore, accessories that are not part of the basic equipment of the product (promotional parts) are excluded from the warranty.

In the event of a warranty claim, please contact us at Hama GmbH & Co KG, Dresdner Str. 9, 86653 Monheim, Germany, enclosing proof of purchase. You are also welcome to contact us at [www.hama.de](http://www.hama.de) or by phone on +49 (0)9091/502-0.