

TV FLOOR STAND

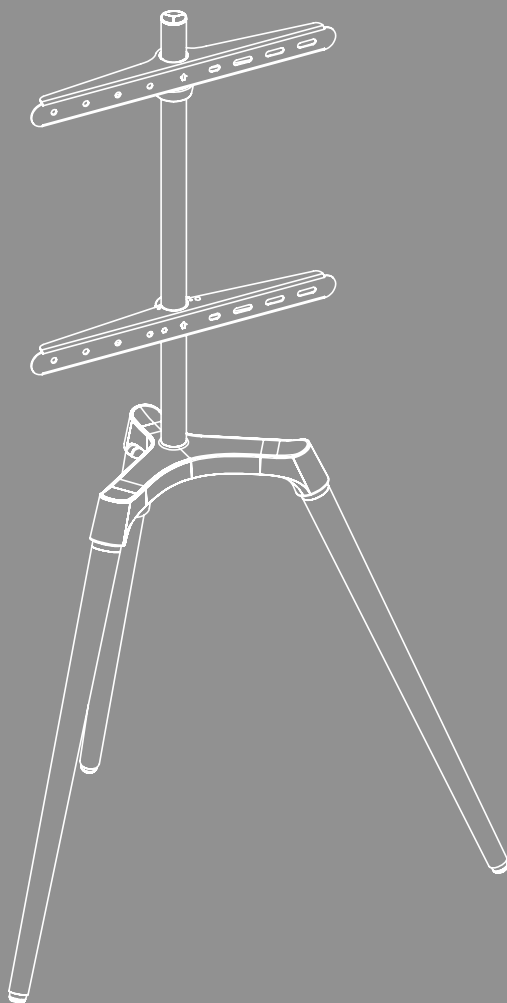



Contents

1. Explanation of warning symbols and notes	3
2. Package contents	4
3. Additionally required tools	4
4. Safety instructions	5
5. Application and specifications	5
6. Preparation and assembly	6
6.1 Assembly preparation	7
6.2 Mounting on the TV set	9
6.3 Mount the VESA arms on the back of the TV set	10
6.4 Mounting the TV on the TV stand	11
6.5 Mounting the cable management	12
7. Adjustment & maintenance	13
8. Setting options	13
9. Technical data	14
10. Warranty disclaimer	15
11. Service and support	15
12. Warranty conditions	15



GB Operating Instructions

Thank you for choosing a Hama product.

Take your time and read the following instructions and information completely. Please keep these instructions in a safe place for future reference. If you sell the device, pass on the illustrated quick start guide and the safety instructions in printed form to the new owner.

1. Explanation of warning symbols and notes

Warning



This symbol is used to indicate safety instructions or to draw your attention to specific hazards and risks.

Note

















This symbol is used to indicate additional information or important notes.



2. Package contents

- VESA arms (2x)
- Support legs (3x)
- Connecting piece (1x)
- Mounting kit
- Safety instructions, illustrated quick start guide

Mounting kit

A1		M6x12 (x4)	B1		M6/M8 (x4)
A2		M6x20 (x4)	B3		Ø8x10 (x8)
A3		M8x12 (x4)	B4		Ø8x20 (x8)
A4		M8x20 (x4)	C1		3 mm (x1)
A5		M8x30 (x4)	C2		4 mm (x1)
A6		M8x50 (x4)*	D1		(x2)
A7		M4x12 (x4)	D2		(x2)
A8		M4x20 (x4)			

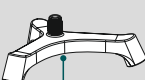

E5 x1

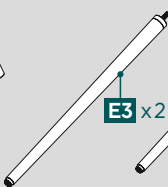

E3 x2

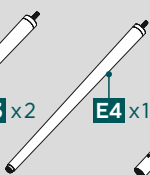

E4 x1

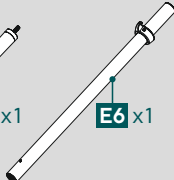

E6 x1

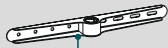

E1 x1

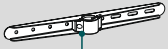

E2 x1

* M8x50 + Ø8x5 = M8x45

Note

Please check the mounting kit for completeness before installing the bracket and ensure that there are no faulty or damaged parts.

3. Additionally required tools



Note

Never install the bracket alone. Seek assistance and help!



4. Safety instructions

Warning



- Given the multitude of terminal devices and wall structures available on the market, the supplied mounting kit is unable to cover every option.
- It occasionally happens that the screws for attaching the device to the bracket are too long.
- Read the operating instructions for your terminal device before attempting to mount it. The instructions provide information about the type and measurements of suitable fastening materials.
- If the supplied mounting kit does not contain suitable fastening materials for mounting the terminal device, purchase these from a specialised dealer.
- Never apply force during assembly. This can damage your device or the bracket.
- If in doubt, have this product installed by a qualified technician - do not attempt to install it yourself!
- Once you have mounted the product and the attached load, check that they are sufficiently secure and safe to use.
- You should repeat this check at regular intervals (at least every three months).
- Ensure that the product does not exceed its maximum permitted carrying capacity and that no load exceeding the maximum permitted dimensions is attached.
- Make sure that the product is loaded symmetrically.
- Maintain the necessary safety clearance around the attached load (depending on the model).
- In the event of damage to the product, remove the attached load and stop using the product.
- Do not attach any additional objects to the product.

5. Application and specifications

- The bracket is used for mounting flat screens in private, non-commercial households.
- The bracket is intended only for use inside buildings.
- Use the bracket only for the intended purpose.



6. Preparation and assembly

Note





- Never install the bracket alone. Seek assistance and help!
- Different end devices have different connections for cabling and other devices. Before commencing the installation, check whether the necessary connections can still be reached after mounting.
- Depending on the product and mounting method, you may not need all parts of the mounting kit. It is therefore possible that unneeded screws and other small parts will be left over even after correct mounting. Keep these in a safe place together with these operating instructions for use for later reference (sale of the product, moving house, relocation of the bracket, new TV, etc.).

Warning



- Only set the product up on even, non-slip surfaces with a sufficient load-bearing capacity for the product and the device attached to it.
- Make sure that children do not use the product for climbing.
- Note that the castors of the product can cause pressure marks on the installation surface. This depends on the weight loading and on the stability of the surface at the place of installation.
- Please note that subsequent height adjustment is only possible by dismantling the suspension fitting.



6.1 Assembly preparation

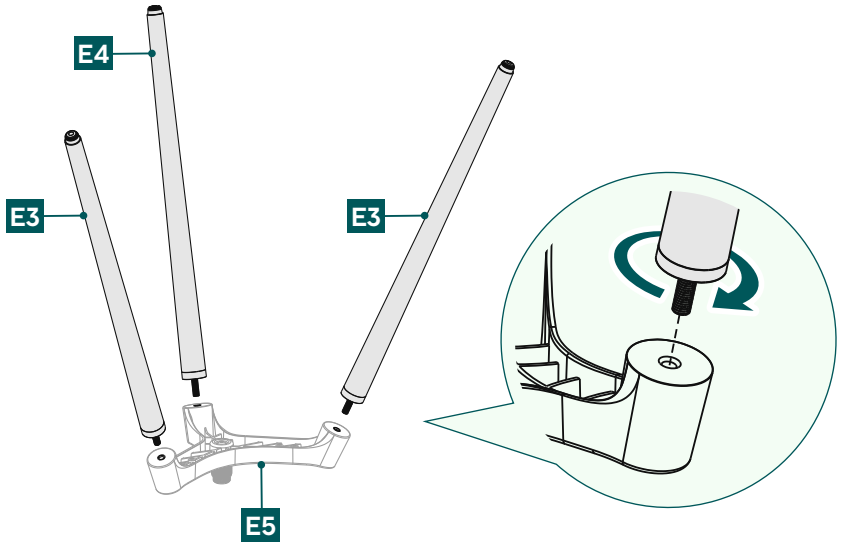

- First screw the three support legs [E3] (2x) and [E4] to the connecting piece [E5] as shown above.

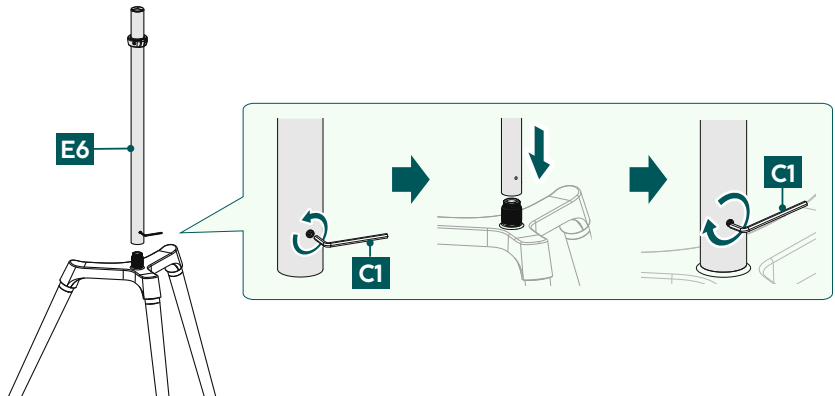

- In the next step, attach the retaining rod [E6] to the connecting piece [E5]. To do this, loosen the screw as shown above using the Allen key [C1]. Now attach the retaining rod [E6] to the connecting piece [E5] and tighten the corresponding screw.

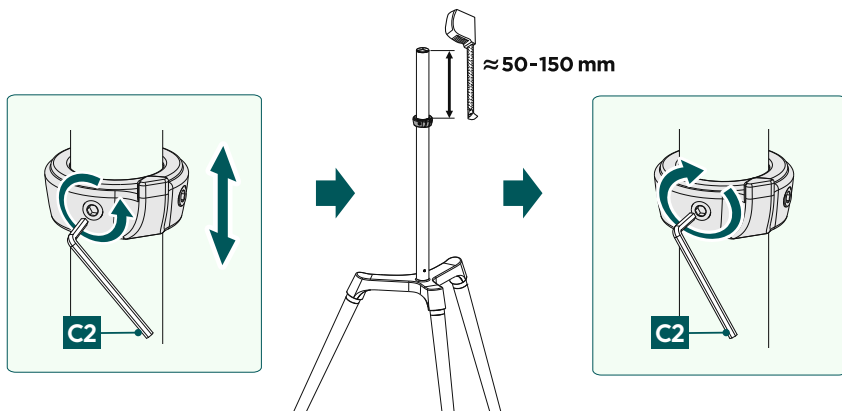

- Use the Allen key [C1] to loosen the locking element as shown above. Bring it to the desired height (depending on the size of the mounted TV) at a distance of approx. 50 - 150 mm from the end of the mounting rod. Then secure the locking element using the Allen key [C1].

6.2 Mounting on the TV set

Note

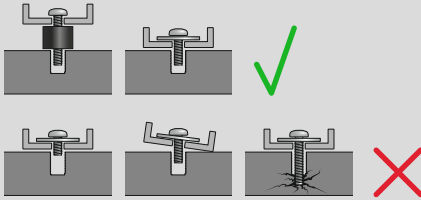

- Given the multitude of terminal devices structures available on the market, we cannot describe all possible mounting options here.
- Please ensure that the bracket lays flat and evenly on the back of the television.
- Use the enclosed spacer to even out any unevenness on the back of the television.
- Ensure that all screws have the proper length and can be mounted until they are hand-tight.



6.3 Mount the VESA arms on the back of the TV set

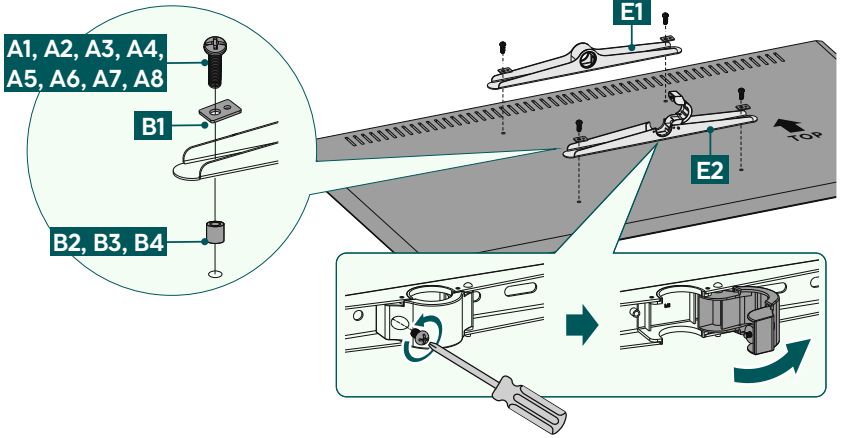

Flat TV back

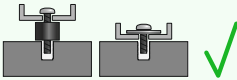
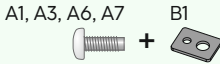

Curved TV back

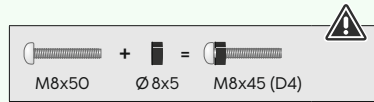
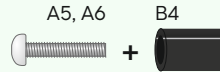
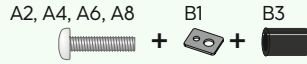

- Please note that the VESA arm [E2] must be attached to the bottom of the TV set. Loosen the safety clip on the VESA arm as shown above using a screwdriver.
- The Vesa arm [E1] is attached to the top of the TV set.
- Mount the VESA arms the back of your TV set.
- Note the combination of screw, washer and spacer listed above for your flat or curved TV.



6.4 Mounting the TV on the TV stand

Get support and help from other people for the following assembly step.

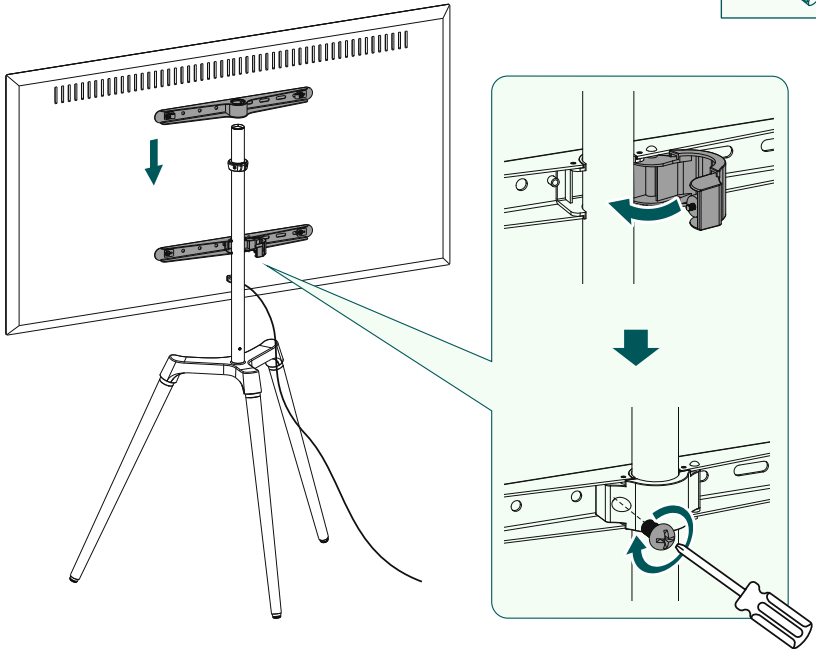

- Hang the TV set with the mounted VESA arms on the bracket as shown above.
- Lock the safety device by closing the previously loosened safety clip and tightening it again using the screw.



6.5 Mounting the cable management

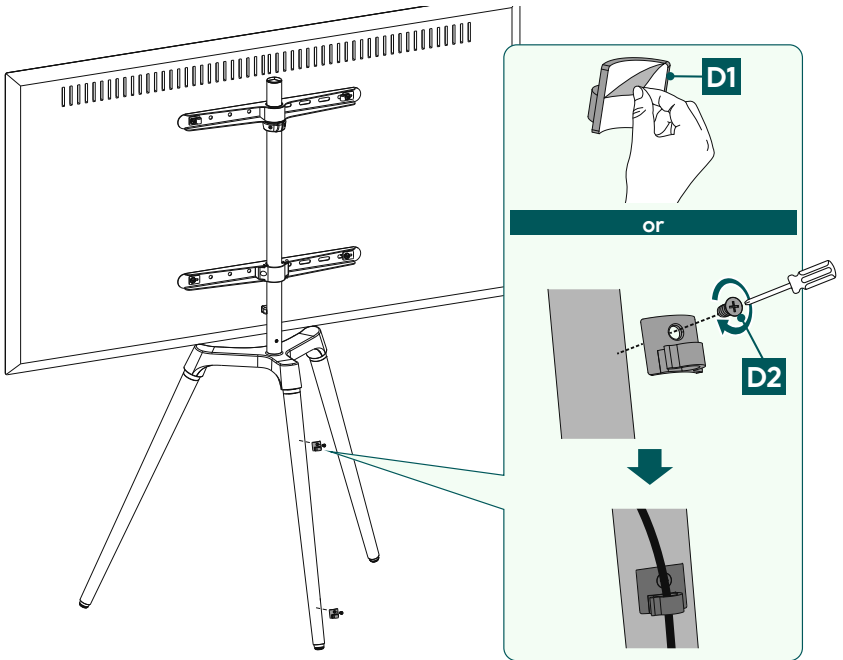

- Attach the supplied cable clips [D1] to the centre leg as shown in the illustration. You have the option of attaching the cable clips using the self-adhesive backing. To do this, remove the protective film, position the cable clip and press it firmly into place. The second way to mount the cable management is to screw it into the desired position using the enclosed screws [D2].
- Then feed the cables through.



7. Adjustment & maintenance

Note

Never adjust the bracket alone. Seek assistance and help!



Note - tiltable / full-motion brackets



- Ensure that no electrical cables are crushed or damaged during installation or adjustment.
 - During adjustment, ensure that the product is loaded symmetrically and that the maximum permitted carrying capacity is not exceeded.
-
- Check the strength and operational safety of the bracket and the load attached to it at regular intervals (at least quarterly).
 - Clean only with water or conventional household cleaners.

8. Setting options

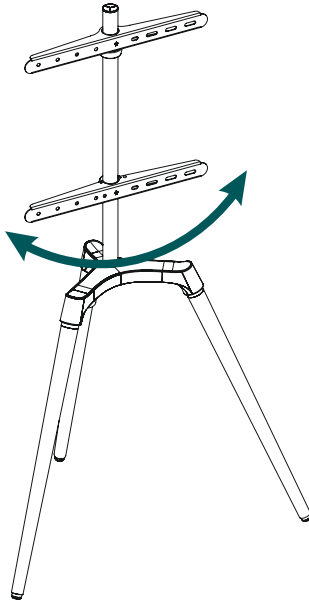

140°
Swivel



9. Technical data

Maximum load:	35 kg
Screen diagonal:	81.0 - 165.0 cm (US: 32" - 65")
Swivel range:	up to 140°
Width:	77.6 cm
Height:	135 cm
Depth:	52.5 cm
Mount:	Compliant with VESA standard: 200x200 300x200 300x300 400x200 400x300 400x400



10. Warranty disclaimer

Hama GmbH & Co KG assumes no liability and provides no warranty for damage resulting from improper installation/mounting, improper use of the product or from failure to observe the operating instructions and/or safety notes.

11. Service and support

Please contact Hama Product Consulting if you have any questions about this product.

Hotline: +49 9091 502-0 (German/English)

Further support information can be found here: www.hama.com

12. Warranty conditions

For this product, HAMA GmbH & Co KG grants you an extended manufacturer's warranty for freedom from defects, usability, workmanship and the durability of the materials used for a period of 10 years. Excluded from the guarantee is the compatibility of the product with future standards of further developed hardware.

Within the specified period, Hama GmbH & Co KG will remedy a justified warranty claim at its own discretion, free of charge, either by repair or replacement.

The warranty period begins on the date of purchase of this product and is valid throughout the EU.

The warranty granted is in addition to and does not affect your statutory rights. Damage caused by improper use, normal wear and tear, exposure to chemicals or force majeure, as well as tampering or repairs by you or third parties, are excluded from the warranty.

Furthermore, accessories that are not part of the basic equipment of the product (promotional parts) are excluded from the warranty.

In the event of a warranty claim, please contact us at Hama GmbH & Co KG, Dresdner Str. 9, 86653 Monheim, Germany, enclosing proof of purchase. You are also welcome to contact us at www.hama.de or by phone on +49 (0)9091/502-0.